

Suzhou Talesun Solar Technologies Co., Ltd.	Technical specifications	
Installation Manual for European	SPEC.NO.	TS-ET-131
	REVISION	A4
	EFFECTIVE DATE	11-2021
		Page 1 of 25

INDEX

1. INTRODUCTION

1.1 PURPOSE OF THE MANUAL	2
1.2 DISCLAIMER OF LIABILITY	2
1.3 PRODUCTION IDENTIFICATION	3

2. SAFETY GUIDELINES

2.1 GENERAL SAFETY GUIDELINES	3
2.2 PRODUCT PRECAUTION	4
2.3 TRANSPORT AND STORAGE SAFETY GUIDELINES	4

3. MECHANICAL INSTALLATION

3.1 SELECTING THE LOCATION	5
3.2 SELECTING THE PROPER SUPPORTING FRAME	5
3.3 GENERAL INSTALLATION	6
3.4 INSTALLATION METHOD	7

4. ELECTRICAL MOUNTING

4.1 MODULE SELECTION	10
4.2 SAFETY FACTOR	10
4.3 GENERAL INSTALLATION	10
4.4 GROUNDING	12

5. COMMISSION AND MAINTENANCE

5.1 BLOCKING DIODES AND BYPASS DIODE	14
5.2 TROUBLESHOOTING	15
5.3 MAINTENANCE	15

Suzhou Talesun Solar Technologies Co., Ltd.	Technical specifications	
Installation Manual for European	SPEC.NO.	TS-ET-131
	REVISION	A4
	EFFECTIVE DATE	11-2021
		Page 2 of 25

1 INTRODUCTION

1.1 PURPOSE OF THE MANUAL

This guide contains information on precautions to be used during the handling and installation of Suzhou Talesun Solar Technologies Co., Ltd. photovoltaic modules along with technical instructions to be followed during installation, mounting, wiring and maintenance thereof. Suzhou Talesun Solar Technologies Co., Ltd. hereafter is referred to as "Talesun". Any divergence from the contents of this manual during the handling, installation, or maintenance of Talesun's products will render the warranty and any guarantees there under null and void.

Information for installers

- ✧ Installers must read and understand this manual before installation.
- ✧ Please ensure that installation, operation and maintenance of your photovoltaic system is only carried out by qualified persons able to carry out the technical procedures described in this manual, i.e. system planers, installers and maintenance personnel, and is carried out in accordance with all safety precautions in this manual and any and all applicable local codes. If you do not possess these qualifications, you may not carry out the work described herein except for cleaning.
- ✧ This manual and the instructions set forth herein are part of the product and should therefore be kept for the entire useful life of the solar installation.

Information for operators

- ✧ Keep these instructions safe for the entire useful life of the solar installation.
- ✧ Please contact your plant supplier for information concerning the formal requirements for solar systems. Please be sure to learn about directives and permit requirements from the responsible local authorities and energy providers prior to installation of the solar plant.
- ✧ We recommend that you insure your solar system against natural hazards (e.g. against lightning strikes).

1.2 DISCLAIMER OF LIABILITY

- ✧ These instructions are only valid for products of Talesun.
- ✧ The information in this manual is based on Talesun's knowledge and experience and is believed to be reliable; but such information including product specification (without limitations) and suggestions do not constitute a warranty, expressed or implied. Talesun reserves the right to change the manual, the PV products, the specifications, or product information sheets without prior notice.
- ✧ Because of the use of this manual and the conditions or methods of installation, operation, use and maintenance of photovoltaic products are beyond Talesun's control, Talesun assumes no liability for damage, loss, or expense arising out of or in any way connected with such installation, operation, use or maintenance. Talesun assumes no responsibility extending beyond the functional capability and safety of the modules. This manual is only for reference.
- ✧ No license is granted by implication or otherwise under any patent or patent rights.
- ✧ Special module's installation according to the module's specification or contract terms.
- ✧ If your questions are not adequately addressed in this manual, please first contact your system supplier. You can find more information on our website www.talesun.com.

Suzhou Talesun Solar Technologies Co., Ltd.	Technical specifications	
Installation Manual for European	SPEC.NO.	TS-ET-131
	REVISION	A4
	EFFECTIVE DATE	11-2021
		Page 3 of 25

1.3 PRODUCTION IDENTIFICATION

Each module has three labels that provide the following information:

- ✧ Nameplate: describes the product type; rated power, rated current, rated voltage, open circuit voltage, short circuit current, all as measured under standard test conditions; weight, dimension etc.; the maximum system voltage is 1000 volts DC is shown on the nameplate. Maximum fuse rating is also shown.
- ✧ “QA Pass” stamp: module will be strictly inspected according to standard and get a QA Pass stamp on the backsheet.
- ✧ 2-dimensional Bar code: The serial number has 16 digits. There are two bar codes on each module. One is permanently attached to the interior of the module and is visible when viewing the front of the module, and another is stuck to the rear side of the module.
- ✧ Removing a label will make the Talesun warranty void.

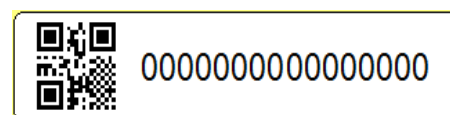

2 SAFETY GUIDELINES

2.1 GENERAL SAFETY GUIDELINES

DANGER! Danger due to electric shock!

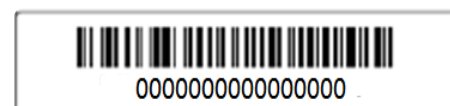

All installations must be performed in compliance with all applicable regional and local codes, or other national or international electrical standards as applicable.

- ✧ A solar module generates electricity and voltage even at low intensity of illumination.
- ✧ Physically disconnecting contacts in a live electrical circuit can cause arcing, resulting in grave or mortal injury. The severity increases when several modules are connected in series.
- ✧ Cover the solar modules with opaque material for the entire duration of assembly. Only then is the module reliably de-energized.
- ✧ Never disconnect plugs when under load. Be aware that even without the presence of daylight, residual charge may still be present in the plant. Ensure that the modules are first disconnected from the inverter prior to opening any contacts in the solar installation.
- ✧ Artificially concentrated sunlight shall not be directed on the module. Solar modules produce electrical energy when light shines on their front and rear surface. The DC voltage may exceed 30V. Contact with a DC voltage of 30V or more is potentially hazardous.
- ✧ In the case of module or phase voltages of more than 120 V, the extra-low voltage range is left. Undertake the necessary protective and precautionary measures.
- ✧ Do not insert electrically conductive parts into the plugs and junction box. Do not touch the contacts or exposed terminals.
- ✧ Keep children and unauthorized persons away from the modules.
- ✧ In case of damaged modules or operational errors of the solar array, always contact your installer or Talesun Technical Customer Service.
- ✧ Do not wear metallic ornaments or metallic devices while installing or troubleshooting photovoltaic systems.

WARNING! Danger of injury due to broken glass! Risk of injury due to falling modules!

Suzhou Talesun Solar Technologies Co., Ltd.	Technical specifications	
Installation Manual for European	SPEC.NO.	TS-ET-131
	REVISION	A4
	EFFECTIVE DATE	11-2021
		Page 4 of 25



The modules are primarily made of glass and must therefore be handled with appropriate caution.

- ✧ In order to ensure safe mounting, familiarize yourself with all applicable national regulations for work safety and accident prevention.
- ✧ Wear suitable protective clothing (e.g. safety shoes, protective gloves) in order to prevent injuries.
- ✧ If the front glass is broken, or the back sheet is torn, contact with any module surface or the frame can cause electric shock.
- ✧ Under normal conditions, a photovoltaic module is likely to experience conditions that produce more current and/or voltage than reported at standard test conditions. Accordingly, the values of I_{sc} and V_{oc} marked on this module should be multiplied by a factor of 1,25 when determining component voltage ratings, conductor current ratings, fuse sizes, and size of controls connected to the PV output.
- ✧ Modules rated for use in this application class may be used in systems operating at greater than 50V DC or 240W, where general contact access is anticipated. Modules qualified for safety through this part of IEC61730 and IEC61730-2 and within this application class are considered to meet the requirements for safety class II .

2.2 PRODUCT PRECAUTION

- ✧ Do not attempt to disassemble the modules.
- ✧ Do not remove any attached nameplates or components from the modules.
- ✧ Do not open the junction box under any circumstances.
- ✧ Only carry out modifications to the modules that have been confirmed by Talesun in writing in advance.
- ✧ Do not carry out any extra drilling (e.g. for fasteners) on the modules.
- ✧ Use only insulated tools that are approved for work on electrical installations.
- ✧ Do not use light concentrators (e.g. mirrors or lenses) to attempt to increase the capacity of the module. The module may be damaged. This also voids the warranty.

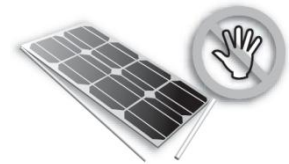

2.3 TRANSPORT AND STORAGE SAFETY GUIDELINES

Inappropriate transport and installation may break the module. To prevent damage of the modules:

- ✧ Transport the modules in their original packaging until installation.
- ✧ Store the modules securely in cool and dry rooms. The packaging is not weather-resistant!
- ✧ Protect the modules against scratches and other damage, especially from impact at the edges or improper storage.
- ✧ Ensure modules do not bow under their own weight.
- ✧ Do not rest a module unprotected on its edges. This can damage the module and the frame.
- ✧ Do not lift or move the modules using the cables or at the junction box under any circumstances!
- ✧ Do not set the modules down hard on any surface.
- ✧ Do not subject the module surfaces to mechanical stress.
- ✧ Do not stand on the modules.
- ✧ Do not drop or place objects on the modules.



3 MECHANICAL INSTALLATION

Suzhou Talesun Solar Technologies Co., Ltd

Address: No. 1 Talesun Road, Changkun Industrial Park, Shajiabang Town, Changshu, Suzhou, Jiangsu Province, 215542, P.R.China

Suzhou Talesun Solar Technologies Co., Ltd.	Technical specifications	
Installation Manual for European	SPEC.NO.	TS-ET-131
	REVISION	A4
	EFFECTIVE DATE	11-2021
		Page 5 of 25

3.1 SELECTING THE LOCATION

- ✧ The modules are certified according to the norm IEC 61215 and others for safe operation in moderate climates. The operator needs to consider the effect of the high altitude on the operation of the module, when the modules are installed at high altitude.
- ✧ Do not expose the modules to chemicals.
- ✧ Do not place the modules in standing water. The projection grade of the junction box is IP68.
- ✧ Do not install the modules near flammable gases and vapors (e.g. gas containers) or near open flames and flammable materials. Solar modules are not explosion-proof operating equipment.
- ✧ If there is exposure to salt (i.e., marine environments) and sulfur (i.e., sulfur sources, volcanoes), there is a risk of corrosion. It's not recommended to install the modules, when the distance is less than 100m; and it's recommended to install the modules with the anti-salt function, when the distance is between 100m and 1km.
- ✧ A module is considered shade-free when it is entirely unshaded throughout the year (e.g. by buildings, chimneys, trees). Even partial shading of the modules (e.g. by overhead lines, dirt, snow) should be avoided.

3.2 SELECTING THE PROPER SUPPORTING FRAME

Always observe the instructions and safety precautions included with the support frames to be used with the modules.

Install each module to a mounting structure:

- ✧ That is made of durable, corrosion-resistant and UV-resistant material.
- ✧ That can transfer forces on the module to the assembly substructure.
- ✧ That ensures that no mechanical stress (e.g. caused by vibrations, twisting or expansion) is generated on the module.
- ✧ That ensures sufficient back ventilation of the module.
- ✧ That ensures long term stability.
- ✧ That will not give rise to galvanic corrosion in case of direct metal contact (i.e. grounding lead, screws, washers, etc.)
- ✧ That allows for strain-free expansion and contraction due to natural ambient temperature variations.

3.3 GENERAL INSTALLATION

Modules connected in series should be installed at the same orientation and angle. Different orientations or angles may cause a loss of power output due to the change in sunlight exposure.

- ✧ When developing the final layout of photovoltaic system, consider keeping suitable access to allow the maintenance and inspection works. To minimize risk in the event of an indirect lightning strike, avoid forming loops when designing the system.
- ✧ The modules may be installed in landscape or portrait format.
- ✧ Install the module in such a way that the junction box is positioned in the upper area of the module and the wires hang downwards.
- ✧ The optimal tilt angle of the module depends on the respective latitude. We recommend a photovoltaic simulation tool to ensure the optimal orientation.

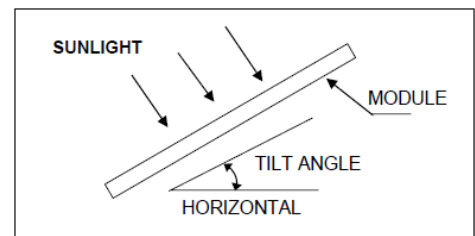

Ground mount

Suzhou Talesun Solar Technologies Co., Ltd.	Technical specifications	
Installation Manual for European	SPEC.NO.	TS-ET-131
	REVISION	A4
	EFFECTIVE DATE	11-2021
		Page 6 of 25

- ✧ Select the height of the mounting system to prevent the lowest edge of the module from being covered by snow for a long time in winter in areas that experience heavy snowfalls.
- ✧ In addition, assure the lowest portion of the module is placed high enough so that it is not shaded by plants or trees or damaged by sand and stones driven by wind.

Roof mount

- ✧ When installing a module on a roof or building, ensure that it is securely fastened and cannot fall as a result of wind or snow loads.
- ✧ Provide adequate ventilation under a module for cooling; the recommended standoff height is 10cm. Clearance of 1/4 of an inch (6.35 mm) or more between modules is required to allow for thermal expansion of the frames.
- ✧ For roof mounting applications the assembly is to be mounted over a fire resistant roof covering rated for the application. Talesun modules have been listed as Class C according to UL790 standard.
- ✧ Any roof penetration required to mount the module must be properly sealed to prevent leaks.
- ✧ In some cases, a special support frame may be necessary.
- ✧ The roof installation of solar modules may affect the fireproofing of the building construction.
- ✧ Do not install modules on a roof or building during strong winds to prevent accidents.
- ✧ All module support structures used to support PV modules at correct tilt angles should be wind and snow load rated by appropriate local and civil codes prior to installation.

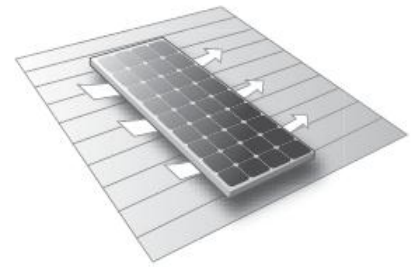

Pole mount

- ✧ When installing a module on a pole, choose a pole and module mounting structure that will withstand anticipated winds for the area.

3.4 INSTALLATION METHOD

Single-sided module is installed using mounting holes, and the mounting structure is perpendicular to the bottom of the long side frame

Bifacial module is installed using both mounting holes and Clamping Installation, To avoid shielding and to comply with load requirements, the installation structure should be mounted parallel under the long side frame

一、Frame Holes Mounting

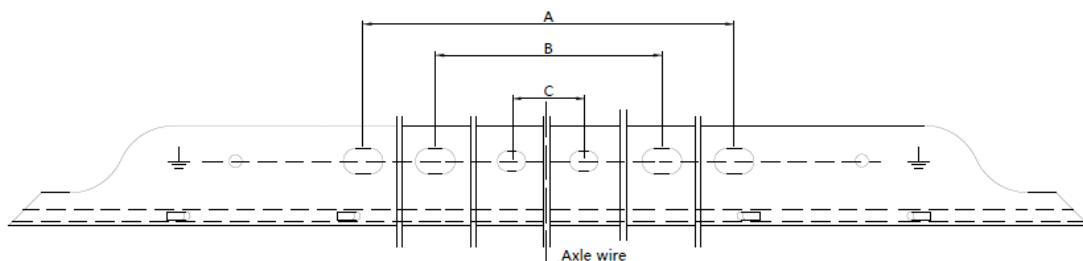

Suzhou Talesun Solar Technologies Co., Ltd

Address: No. 1 Talesun Road, Changkun Industrial Park, Shajiabang Town, Changshu, Suzhou, Jiangsu Province, 215542, P.R.China

Suzhou Talesun Solar Technologies Co., Ltd.	Technical specifications	
Installation Manual for European	SPEC.NO.	TS-ET-131
	REVISION	A4
	EFFECTIVE DATE	11-2021
		Page 7 of 25

The position of Frame Holes

组件型号	安装孔	孔距
TP6F60M 系列	A	1290±1
	B	990±1
TP6F72M 系列	A	1620±1
	B	1300±1
TP6G60M 系列	A	1290±1
	B	990±1
TP6G72M 系列	A	1620±1
	B	1300±1
TD6G60M 系列	A	1290±1
	B	990±1
TD6G72M 系列	A	1620±1
	B	1300±1
TP6L60M 系列	A	1290±1
	B	990±1
	C	400±1
TP6L72M 系列	A	1620±1
	B	1300±1
	C	400±1
TD6I60M 系列	A	1290±1
	B	990±1
	C	400±1
TD6I72M 系列	A	1620±1
	B	1300±1
	C	400±1
TP7F54M系列	A	1400±1
	B	990±1
	C	400±1
TD7G54M系列	A	1400±1
	B	990±1
	C	400±1
TP7F60M系列	A	1400±1
	B	990±1
	C	400±1
TD7G60M系列	A	1400±1
	B	990±1

Suzhou Talesun Solar Technologies Co., Ltd.	Technical specifications	
Installation Manual for European	SPEC.NO.	TS-ET-131
	REVISION	A4
	EFFECTIVE DATE	11-2021
		Page 8 of 25

	C	400 ± 1
TP7F66M系列	A	1400 ± 1
	B	990 ± 1
	C	400 ± 1
TD7G66M系列	A	1400 ± 1
	B	990 ± 1
	C	400 ± 1
TP7F72M系列	A	1400 ± 1
	B	990 ± 1
	C	400 ± 1
TD7G72M系列	A	1400 ± 1
	B	990 ± 1
	C	400 ± 1
TP7F78M系列	A	1400 ± 1
	B	990 ± 1
TD7G78M系列	A	1400 ± 1
	B	990 ± 1

- I. Use mounting holes of A or B
The modules have been designed a positive design load of 3600 Pa and negative design load of 1600 Pa with safety factor $\gamma_{m=1,5}$, and this value can decrease if modules are not mounted following the instructions above.
- II. Use mounting holes of C
The modules have been designed a positive design load of 1600 Pa and negative design load of 1600 Pa with safety factor $\gamma_{m=1,5}$, and this value can decrease if modules are not mounted following the instructions above.

Modules must be securely attached to the mounting structure using six pre-drilled mounting holes in the frame.

- ✧ Modules should be bolted to support structures through mounting holes located in the frame's back flanges only. Do not drill additional holes. Doing so will void the warranty.
- ✧ Each module must be securely fastened at a minimum of 4 points. If additional wind or snow loads are anticipated for this installation, additional mounting points should be used. System designer and installer are responsible for load calculations and for proper design of support structure.
- ✧ Use appropriate corrosion resistant fastening materials. All mounting hardware (bolts/split washers/flat washers/nuts) shall be of stainless steel M8 size. Flat washers with diameters of 12-16mm and thickness ≥ 1.8 mm should be used for parts in contact with the frame. Flat washers of 16mm diameter should be used for large cavity 30 and 35 frames of type 72.
- ✧ Follow mounting guidelines recommended by the PV mounting supplier. The mounting design must be certified by a registered professional engineer.

Suzhou Talesun Solar Technologies Co., Ltd

Address: No. 1 Talesun Road, Changkun Industrial Park, Shajiang Town, Changshu, Suzhou, Jiangsu Province, 215542, P.R.China

Suzhou Talesun Solar Technologies Co., Ltd.	Technical specifications	
Installation Manual for European	SPEC.NO.	TS-ET-131
	REVISION	A4
	EFFECTIVE DATE	11-2021
		Page 9 of 25

- ◇ The mounting design and procedures shall comply with local codes and all authorities having jurisdiction.
- ◇ Use a torque wrench for installation. Tightening torques should be within 16~20Nm for M8 coarse thread bolts, depending on bolt quality class.

a) Single-sided module

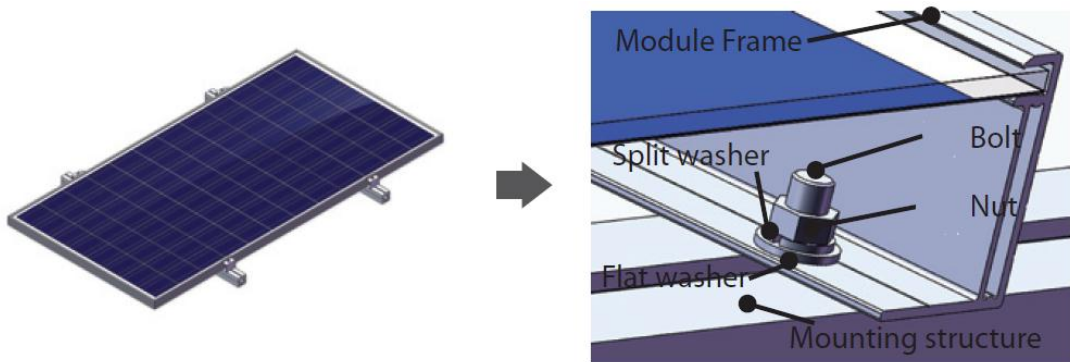

Use mounting holes of A or B(Apply to all series)

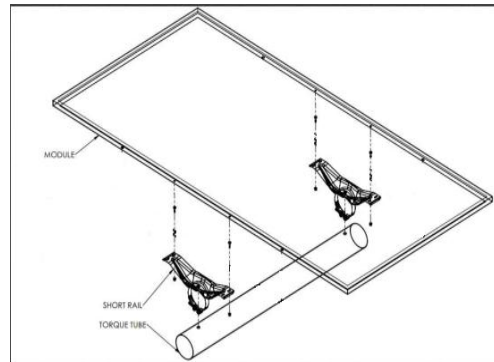
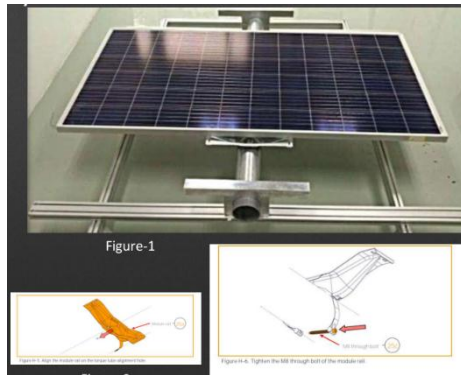

Use mounting holes of C(Apply to TP6L60/TP6L72 series)

b) Bifacial module

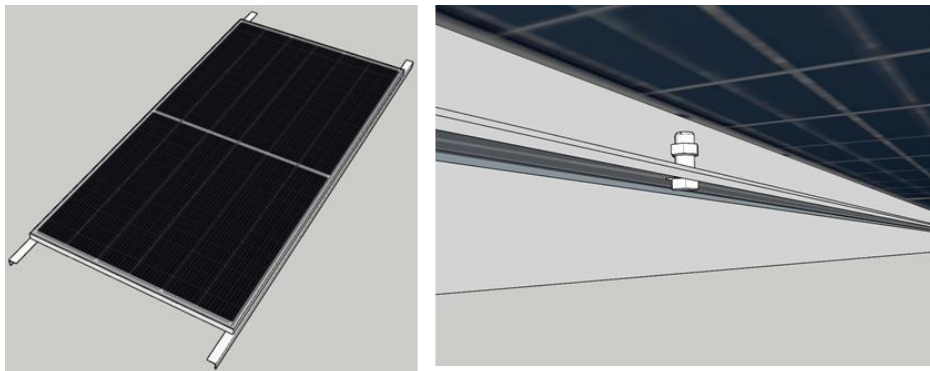

Use mounting holes of A or B(Apply to all series)

Suzhou Talesun Solar Technologies Co., Ltd.	Technical specifications	
Installation Manual for European	SPEC.NO.	TS-ET-131
	REVISION	A4
	EFFECTIVE DATE	11-2021
		Page 10 of 25

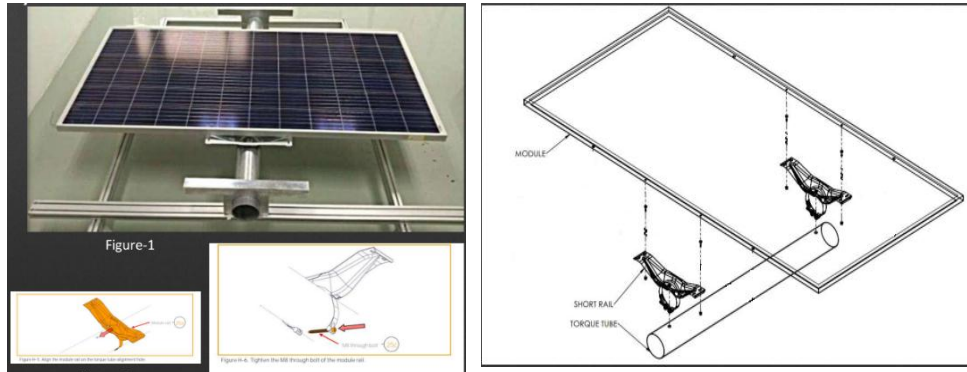

Use mounting holes of C(Apply to TD6I60/TD6I72 series)

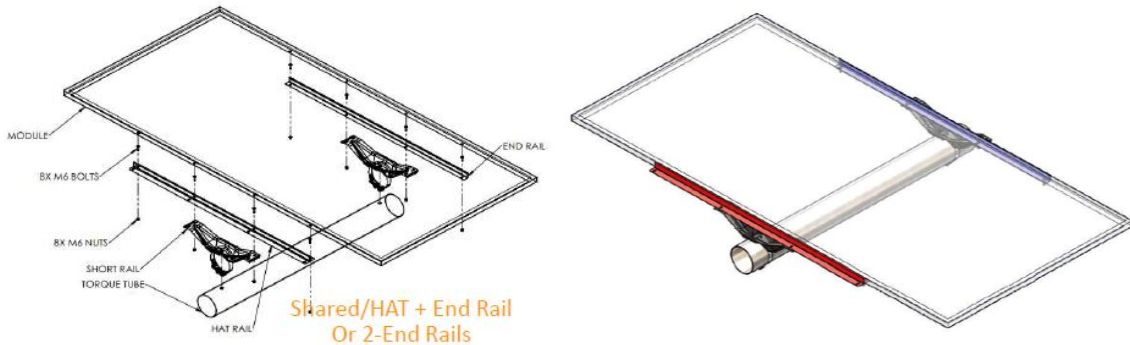
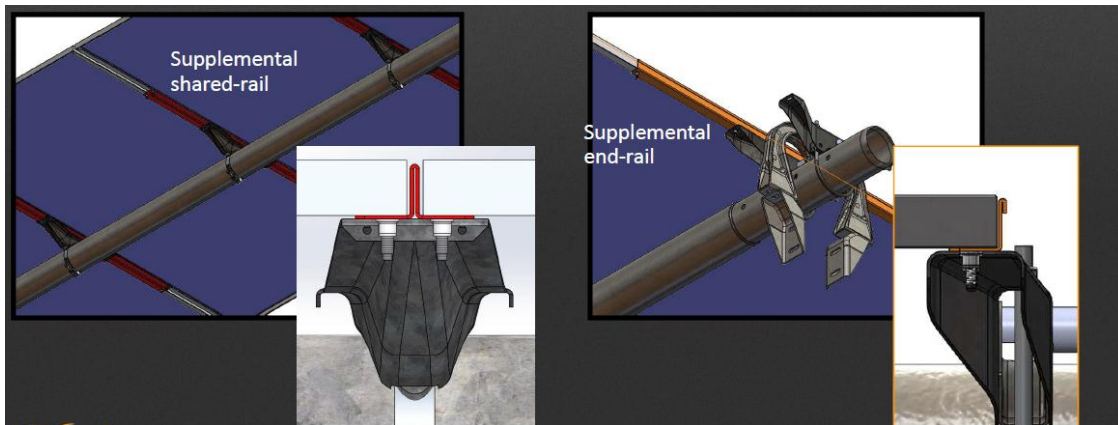

Use mounting holes of C(Apply to TD7G54/ TD7G60/ TD7G66/ TD7G72 series)

- ✧ Ensure that the drainage openings of the frame are left open following installation to allow water runoff. This prevents frost damage.
- ✧ Install the module in such a way that rainwater and snowmelt can run off freely to avoid standing water or puddling.
- ✧ The modules have been designed to resist a static load of positive 3600Pa and negative 1600Pa with safety factor $\gamma_m=1.5$, and this resistance value can decrease if modules are not mounted following the instructions above.

Suzhou Talesun Solar Technologies Co., Ltd

Address: No. 1 Talesun Road, Changkun Industrial Park, Shajiabang Town, Changshu, Suzhou, Jiangsu Province, 215542, P.R.China

Suzhou Talesun Solar Technologies Co., Ltd.	Technical specifications	
Installation Manual for European	SPEC.NO.	TS-ET-131
	REVISION	A4
	EFFECTIVE DATE	11-2021
		Page 11 of 25

二、Clamping installation

Modules can be clamped in. Modules must be securely attached to the mounting structure with at least four clips on the frame.

- ✧ The modules must be properly secured to their support so that they can withstand live load condition, including wind uplift, to the pressure they have been certified for. It's the installer's responsibility to ensure the clamps used to secure the modules are strong enough.
- ✧ The modules are not subject to wind or snow loads exceeding the maximum permissible loads.
- ✧ The module clamps which are used must not come into contact with the front glass and must not deform the frame. Avoid shadowing effects from the module clamps. Drain holes in the module frame must not be closed or obscured by the clamps.
- ✧ The module installed with clamps on long frame have been designed to resist a static load of positive 3600Pa and negative 1600Pa with safety factor $\gamma_m=1,5$, The module installed with clamps on short frame have been designed to resist a static load of positive 1600Pa and negative 1067Pa with safety factor $\gamma_m=1,5$, and refer to the following table for different value of "A" and "B".

(a) Single-sided module (long frame)

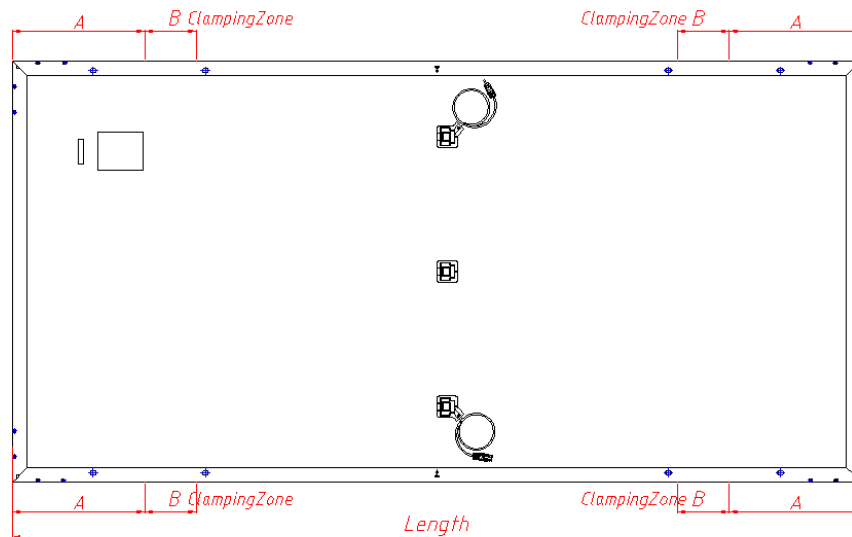

Component type	Component size Length*width*height	Load 1.5 safety factor	A From the edge of the component to Distance of installation area	B Installation area
TP6F60	1665mm*1002mm*35mm	3600Pa front	250mm	100mm

Suzhou Talesun Solar Technologies Co., Ltd.	Technical specifications	
Installation Manual for European	SPEC.NO.	TS-ET-131
	REVISION	A4
	EFFECTIVE DATE	11-2021
		Page 12 of 25

		1600Pa back	250mm	100mm
TP6F72	2008mm*1002mm*35mm	3600Pa front	400mm	100mm
		1600Pa back	400mm	100mm
TP6L72	2094mm*1038mm*35mm	3600Pa front	440mm	100mm
		1600Pa back	440mm	100mm
TP6L60	1755mm*1038mm*35mm	3600Pa front	290mm	100mm
		1600Pa back	290mm	100mm
TP7F60	1908*1134*35mm 1891*1134*35mm	3600Pa front	380mm	100mm
		1600Pa back	380mm	100mm
TP7F66	2094*1134*35mm 2074*1134*35mm	3600Pa front	420mm	100mm
		1600Pa back	420mm	100mm
TP7F72	2279*1134*35mm 2257*1134*35mm	3600Pa front	520mm	100mm
		1600Pa back	520mm	100mm
TP7F78	2465*1134*35mm 2440*1134*35mm	3600Pa front	560mm	100mm
		1600Pa back	560mm	100mm
TP7F54	1722*1134*30	3600Pa front	270mm	100mm

Suzhou Talesun Solar Technologies Co., Ltd.	Technical specifications	
Installation Manual for European	SPEC.NO.	TS-ET-131
	REVISION	A4
	EFFECTIVE DATE	11-2021
		Page 13 of 25

1600Pa back	270mm	100mm
----------------	-------	-------

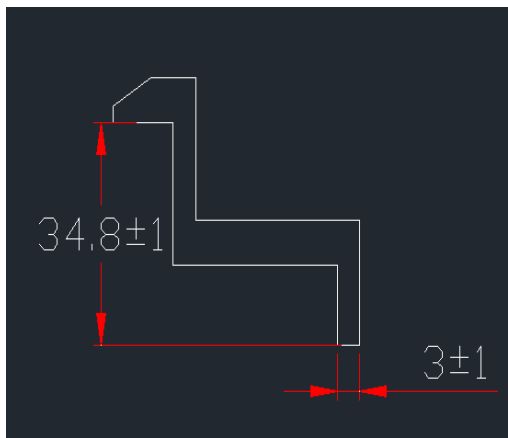
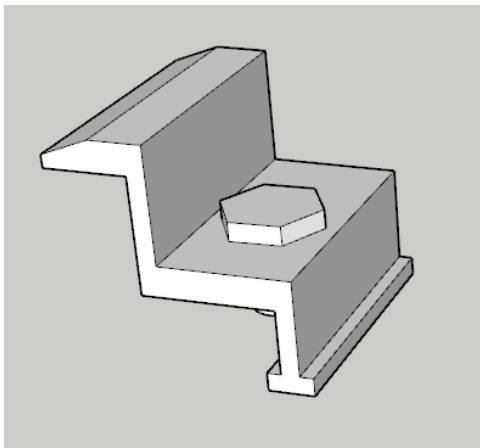
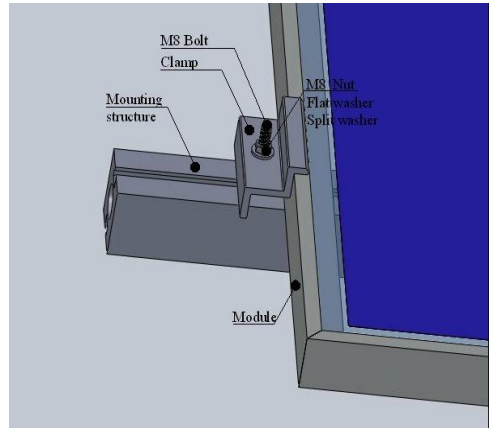
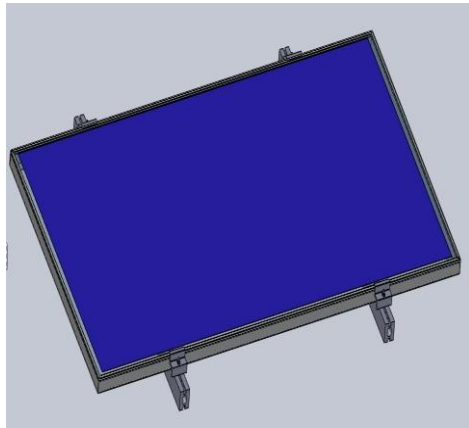

(b) Single-sided module (short frame)

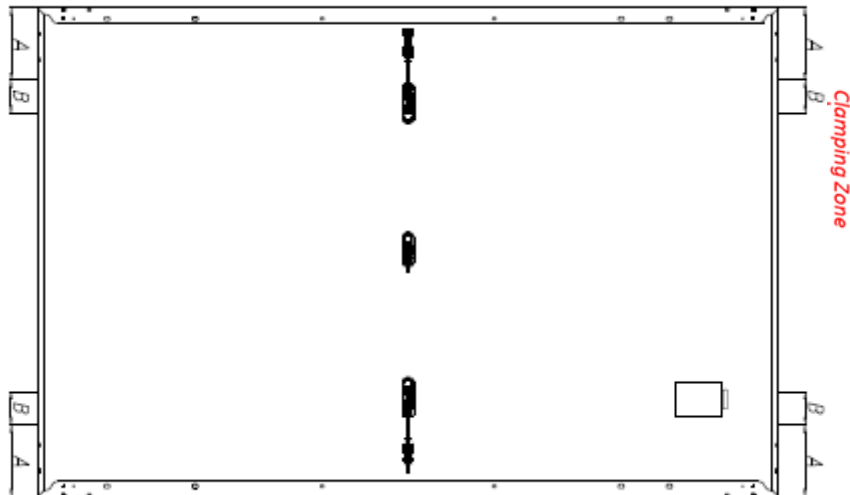

Suzhou Talesun Solar Technologies Co., Ltd.	Technical specifications	
Installation Manual for European	SPEC.NO.	TS-ET-131
	REVISION	A4
	EFFECTIVE DATE	11-2021
		Page 14 of 25

Component type	Component size Length*width*height	Load 1.5 safety factor	A From the edge of the component to Distance of installation area	B Installation area
TP7F54	1722mm*1134mm*30mm	1600Pa front	100mm	140mm
		1067Pa back	100mm	140mm

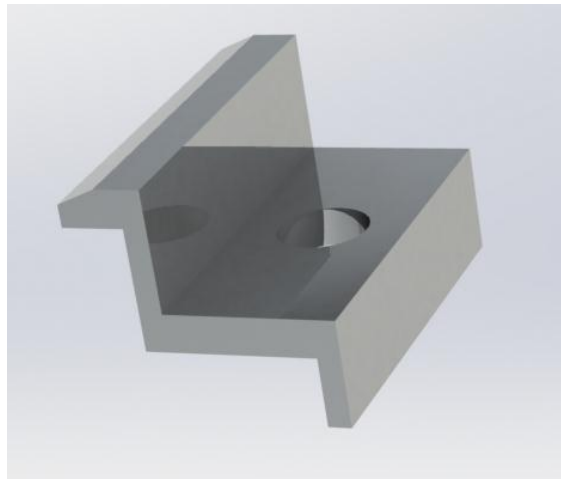
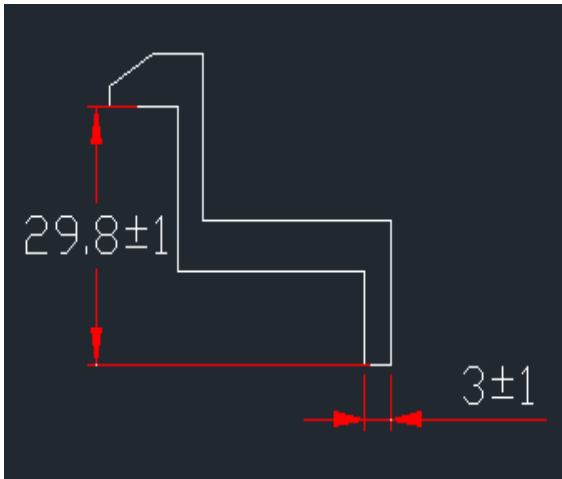
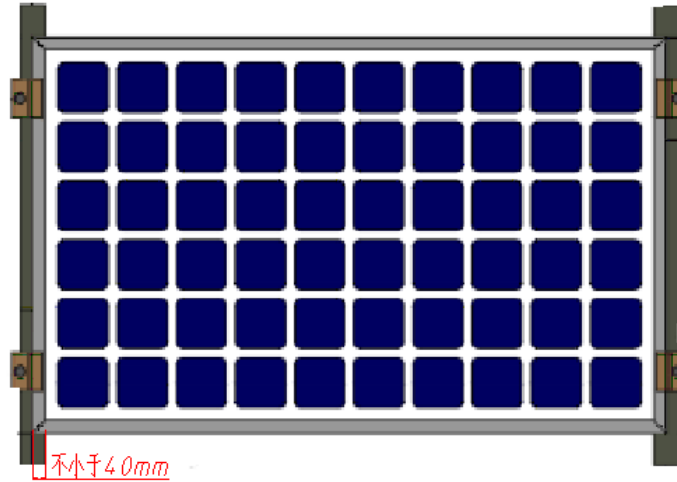

Suzhou Talesun Solar Technologies Co., Ltd.	Technical specifications	
Installation Manual for European	SPEC.NO.	TS-ET-131
	REVISION	A4
	EFFECTIVE DATE	11-2021
		Page 15 of 25

(c) Bifacial module

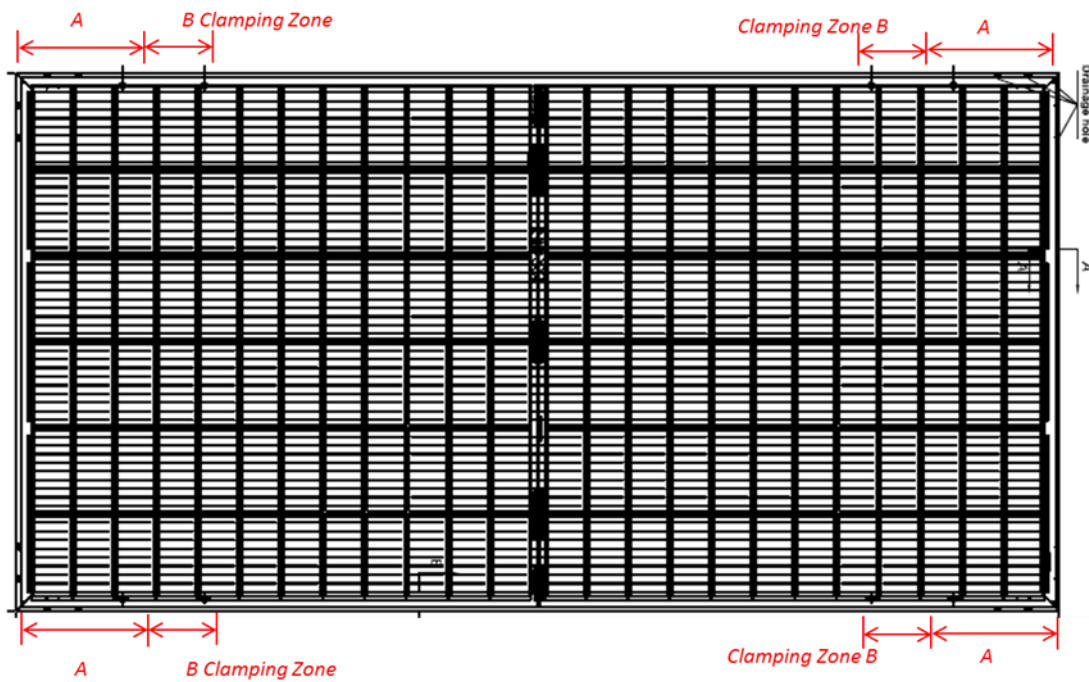

Component type	Component size Length*width*height	Load 1.5 safety factor	A From the edge of the component to Distance of installation area	B Installation area
TP6G60M	1704mm*1008mm*35mm	3600Pa front	270mm	100mm
		1600Pa back	270mm	100mm
TP6G72M	2030mm*1008mm*35mm	3600Pa front	430mm	100mm

Suzhou Talesun Solar Technologies Co., Ltd

Address: No. 1 Talesun Road, Changkun Industrial Park, Shajiabang Town, Changshu, Suzhou, Jiangsu Province, 215542, P.R.China

Suzhou Talesun Solar Technologies Co., Ltd.	Technical specifications	
Installation Manual for European	SPEC.NO.	TS-ET-131
	REVISION	A4
	EFFECTIVE DATE	11-2021
		Page 16 of 25

		1600Pa back	430mm	100mm
TD6G72M	2031mm*1011mm*30mm	3600Pa front	430mm	100mm
		1600Pa back	430mm	100mm
TD6G60M	1705mm*1011mm*30mm	3600Pa front	270mm	100mm
		1600Pa back	270mm	100mm
TD6I72M	2094mm*1038mm*30mm	3600Pa front	455mm	100mm
		1600Pa back	455mm	100mm
TD6I60M	1755mm*1038mm*30mm	3600Pa front	290mm	100mm
		1600Pa back	290mm	100mm
TD7G78M	2471mm*1134mm*35mm 2440mm*1134mm*35mm	3600Pa front	500mm	100mm
		1600Pa back	500mm	100mm
TD7G72M	2285mm*1134mm*35mm 2257mm*1134mm*35mm	3600Pa front	460mm	100mm
		1600Pa back	460mm	100mm
TD7G66M	2100mm*1134mm*35mm 2074mm*1134mm*35mm	3600Pa front	420mm	100mm
		1600Pa back	420mm	100mm

Suzhou Talesun Solar Technologies Co., Ltd

Address: No. 1 Talesun Road, Changkun Industrial Park, Shajiabang Town, Changshu, Suzhou, Jiangsu Province, 215542, P.R.China

Suzhou Talesun Solar Technologies Co., Ltd.	Technical specifications	
Installation Manual for European	SPEC.NO.	TS-ET-131
	REVISION	A4
	EFFECTIVE DATE	11-2021
		Page 17 of 25

TD7G60M	1914mm*1134mm*35mm	3600Pa front	380mm	100mm
	1891mm*1134mm*35mm	1600Pa back	380mm	100mm

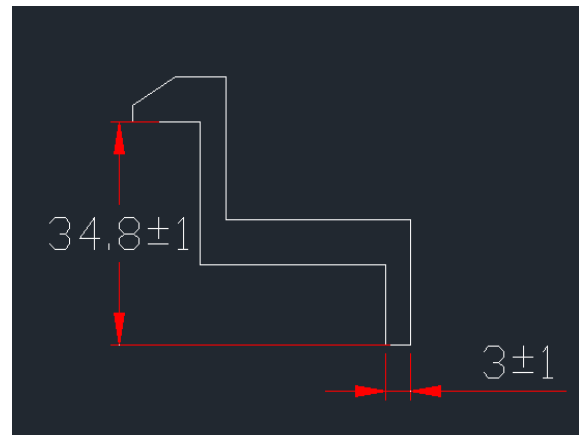
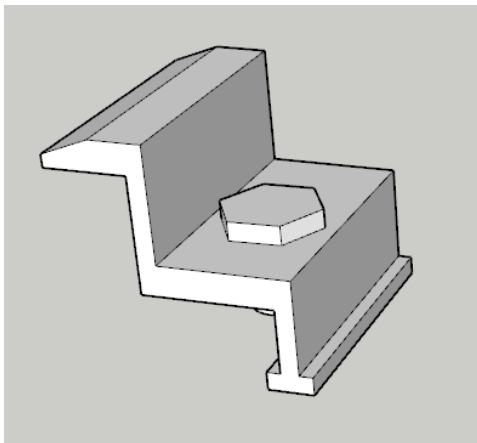
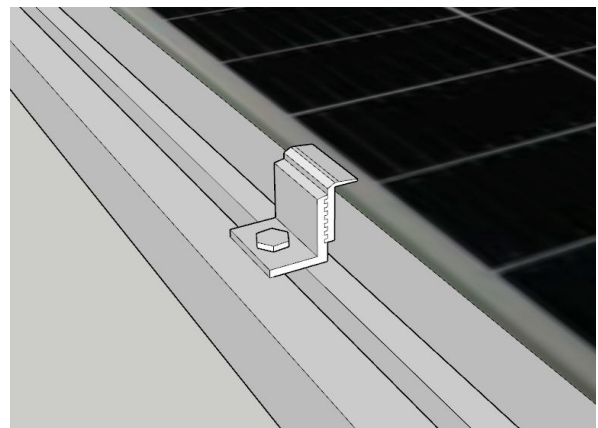
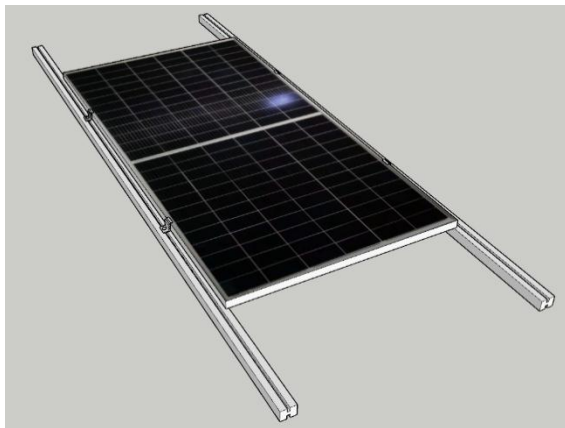

- ✧ Use a torque wrench for installation, and the compression for each clamps is not strong to avoid potential damages to module frames. The recommended maximum compression for each clamp is 20MPa (2900PSI).
- ✧ The module mounting structure must be made of durable, corrosion-resistant and UV-resistant material. All mounting hardware (bolt/flat washer/split washer/nut) should be stainless steel M8 size, Tightening torques should be within 16~20Nm
- ✧ The minimum recommended length for each clamp is 50mm.
- ✧ The module installed with clamps on long frame have been designed to resist a static load of positive 3600Pa and negative 1600Pa with safety factor $\gamma_{m=1,5}$, The module installed with clamps on short frame have been designed to

Suzhou Talesun Solar Technologies Co., Ltd.	Technical specifications	
Installation Manual for European	SPEC.NO.	TS-ET-131
	REVISION	A4
	EFFECTIVE DATE	11-2021
		Page 18 of 25

resist a static load of positive 1600Pa and negative 1067Pa with safety factor $\gamma_{m=1,5}$ and the resistance value can decrease if modules are not mounted following the instruction above.

- ✧ This manual is just for reference. Customer can select the corresponding installation manual based on the purchased module.

4 ELECTRICAL INSTALLATION

4.1 MODULE SELECTION

Only connect modules of the same type, same configurations and same power class in the same system. This is the only way to achieve optimal yields.

4.2 SAFTY FACTOR

Under normal conditions, a photovoltaic module may experience conditions that produce more current and/or voltage than reported at Standard Test Conditions. Accordingly, the values of I_{sc} and V_{oc} marked on modules should be multiplied by a factor of 1.25 when determining component voltage ratings, conductor capacities, fuse sizes and size of controls connected to the module output.

Alternatively, all valid national regulations for the installation of electrical systems are to be applied.

Installer need to pay more attention to avoid the PID phenomenon, when installing the electrical system.

4.3 GENERAL INSTALLATION

- ✧ Before installing modules, contact the appropriate authorities to determine permissions, installation and inspection requirements to follow that apply to your site and installation.
- ✧ Check applicable building codes to ensure that the construction or structure (roof, facade, support, etc.) where the modules are being installed is strong enough to support the weight of the modules and all other system components.
- ✧ When a high voltage needs to be obtained, several PV modules can be connected in series with the total voltage equal to the sum of their voltages. However, the maximum system voltage must be lower than the highest certified voltage and the maximum input voltage for inverters and other electrical equipment in the installed system. The maximum number of modules in series is $(N) = \text{System } V_{max} / \{V_{oc} (\text{at STC}) \times [1 + (t - 25) * K_v]\}$, where:
 - N: Number of modules in series
 - V_{oc} (at STC): Open circuit voltage of each module (refer to product label or data sheet)
 - K_v : Thermal coefficient of open circuit voltage for the module (refer to data sheet)
 - t: The lowest expected ambient temperature
- ✧ If the modules are allowed to be installed in parallel electrically, each module (or series string of modules so connected) shall be provided with the maximum series fuse as specified. For applications requiring high currents, several photovoltaic modules can be connected in parallel; the total current is equal to the sum of individual currents, each module (or series string of modules so connected) shall be provided with the maximum series fuse as specified. The recommended number of module in parallel is only one.
- ✧ Use special solar cable and suitable plugs only (wiring should be placed in conduit that is sunlight-resistant or, if exposed, should be sunlight-resistant) in accordance with local fire, building and electrical codes. Ensure that they are

Suzhou Talesun Solar Technologies Co., Ltd.	Technical specifications	
Installation Manual for European	SPEC.NO.	TS-ET-131
	REVISION	A4
	EFFECTIVE DATE	11-2021
		Page 19 of 25

in perfect electrical and mechanical condition.

- ✧ Only use solar cables as connection cables. Use connectors of the same type and manufacturer within a solar system, and compatible connectors to connect the inverter. During the installation, disassembly, maintenance and any other related processes of cables and connectors, the force applied between cables and connectors shall not be more than 50N, so as to avoid improper connection or damage of connectors and cables caused by human factors, affecting the electrical safety or service life of products.
- ✧ Ensure that all electrical components are in a proper, dry and safe condition. In this way you avoid electrical short-circuits or dangerous contact voltages due to defective or damaged cables.
- ✧ Always avoid mechanical stressing of the connection cables.
- ✧ Ensure a tight connection between the individual connectors (especially to the inverter). Make sure they click together properly.

4.4 GROUNDING

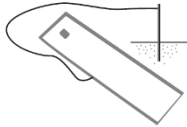
- ✧ The module frame must be properly grounded. The grounding wire must be properly fastened to the module frame to assure good electrical contact. Use the recommended type, or an equivalent, connector for this wire. 
- ✧ Polarity negative ground of the inverter in the system is able to effectively avoid the PID phenomenon of the module in addition, and professional person is needed to undertake the polarity negative ground operation of the inverter.

- ✧ If the support frame is made of metal, the surface of the frame must be electroplated and have excellent conductivity.
- ✧ Grounding clip assembly (TYPE: TYCO ELECTRONICS 1954381-2).
- ✧ the minimum bending radius of the cable is 43mm

Wire selection and preparation:

The grounding clip accepts solid uninsulated copper wire sizes 1*4mm². The wire must not be nicked, cut, or scraped. There is no preparation required.

Spacing:

Care must be used to avoid interference between adjacent grounding clips and other components for removal of the grounding clip.

Removal:

The wire can be removed from the grounding clip when the slider is disengaged (slider and screw are exposed). The screw must be loosened before the grounding clip can be removed from the frame. The grounding clip can be reused up to 5 times after proper removals (the 8--32 screw and hex nut or Keps nut can be reused; however, the thread-



Suzhou Talesun Solar Technologies Co., Ltd

Suzhou Talesun Solar Technologies Co., Ltd.	Technical specifications	
Installation Manual for European	SPEC.NO.	TS-ET-131
	REVISION	A4
	EFFECTIVE DATE	11-2021
		Page 20 of 25

screw cannot be reused after removing the grounding clip from the frame.

Repair:

The grounding clip is not repairable. Discard any defective or damaged grounding clips.

Tooling:

A drill bit is required for drilling the frame holes. A No. 2 cross--recessed screwdriver must be used to secure (and remove) the screw of the grounding clip to (and from) the frame. For the grounding clip with the 8--32 screw and hex nut or Keps nut, a 3/8--in. wrench must be used to secure (and remove) the nut of the grounding clip to (or from) the frame. The recommended screw tightening torque is 1.7+0.5/-0.2Nm (15+4.4/-1.7 in.-lbs).

The slider can be engaged manually or channel lock pliers can be used to engage the slider. A flat--head screwdriver must be used to disengage the slider.

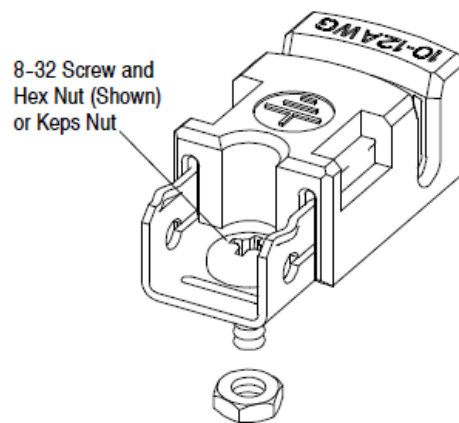

Suzhou Talesun Solar Technologies Co., Ltd.	Technical specifications	
Installation Manual for European	SPEC.NO.	TS-ET-131
	REVISION	A4
	EFFECTIVE DATE	11-2021
		Page 21 of 25

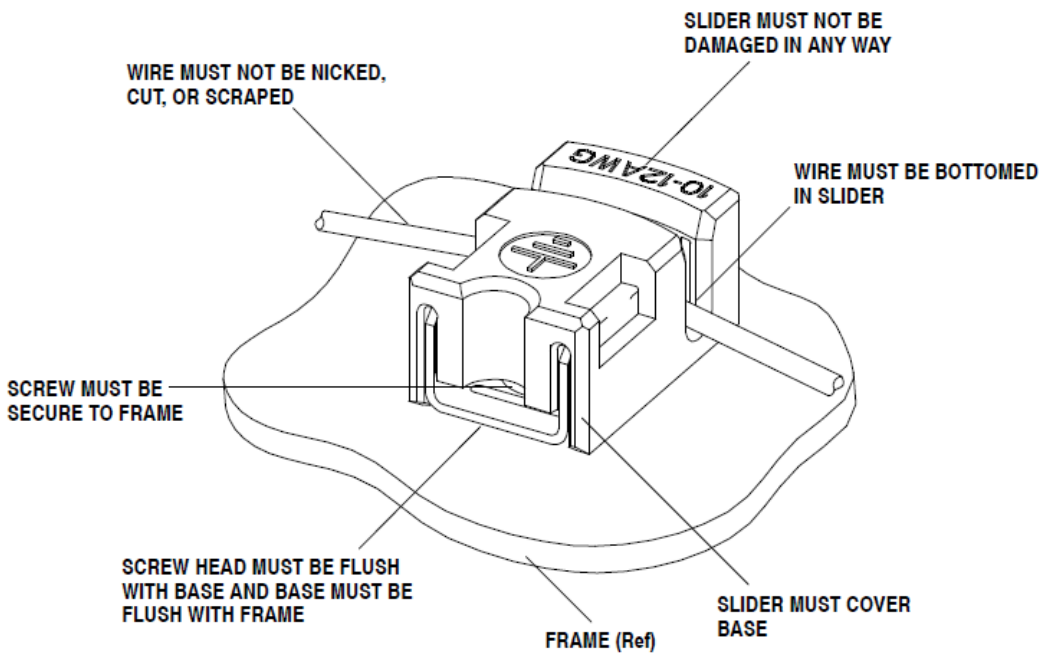

Mounting

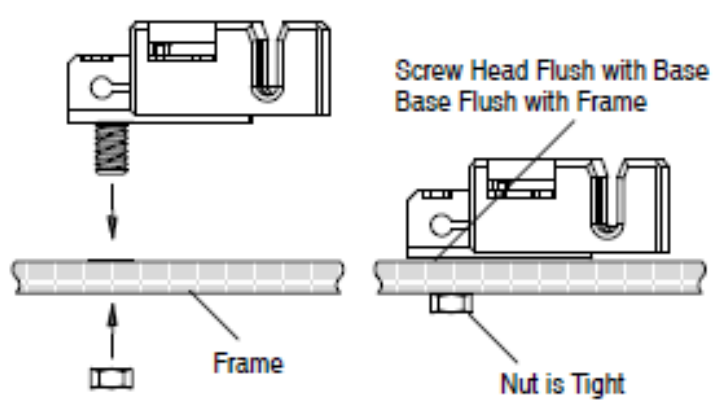

Suzhou Talesun Solar Technologies Co., Ltd.	Technical specifications	
Installation Manual for European	SPEC.NO.	TS-ET-131
	REVISION	A4
	EFFECTIVE DATE	11-2021
		Page 22 of 25

Wire Placement

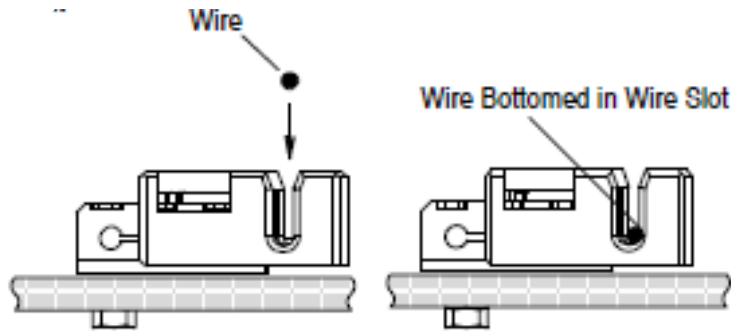

Termination

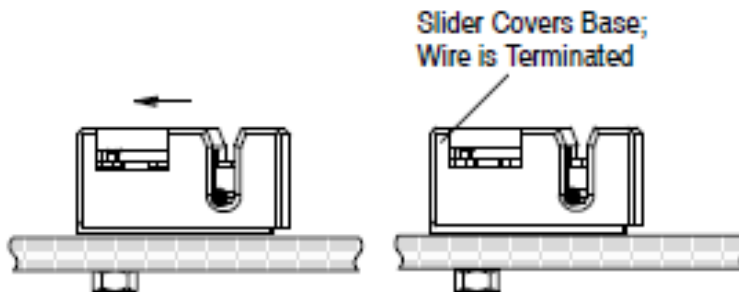

Suzhou Talesun Solar Technologies Co., Ltd.	Technical specifications	
Installation Manual for European	SPEC.NO.	TS-ET-131
	REVISION	A4
	EFFECTIVE DATE	11-2021
		Page 23 of 25

5 COMMISSION AND MAINTENANCE

5.1 BLOCKING DIODES AND BYPASS DIODES

- ✧ Blocking diodes prevent current flowing from the battery to the module when no electricity is being generated. It is recommended to use blocking diodes when a charging regulator is not used. Your specialist dealer can advise you regarding the suitable types.
- ✧ In systems with more than two modules in series, high reverse current can flow through cells that are shaded partially or outright when part of a module is shaded and the rest is exposed to the sun. These currents can cause the affected cells to get very hot and could even damage the module. To protect module from such high reverse currents, by-pass diodes are used in modules. All modules rated greater than 55 Watt have bypass diodes already integrated in the junction box. In the unlikely event of diode failure, it can be easily replaced; however, doing so will void warranty unless this exchange is made by an authorized person.
- ✧ Protect yourself from electric shocks while debugging or maintaining the solar power system.

Bypass diode type	Manufacturer
GF3045	Jiangsu Weierfu Electronic Technology Co., Ltd.

5.2 TROUBLESHOOTING



DANGER! Life danger due to electric shock!

- ✧ Please do not attempt to correct problems on your own!
- ✧ In case of problems or damaged modules (for example, glass breakage, damaged cables) please contact your installer or the Talesun Technical Customer Service.

5.3 MAINTENANCE

Talesun modules are built to last and require minimal maintenance. The dirt is typically washed away by rain. However, rain may not adequately clear more stubborn grime (i.e. pollen, vegetation, bird droppings, etc.). Such soiling which shades the active area of the module can lead to a reduction in the system's performance. Talesun recommends the following maintenance in order to ensure optimum performance of the module:

- ✧ Clean the glass surface of the module as necessary. Always use water and a soft sponge or cloth for cleaning. A mild, non-abrasive cleaning agent can be used to remove stubborn dirt.
- ✧ Check the electrical and mechanical connections every six months to verify that they are clean, secure and undamaged.
- ✧ If any problem arises, have them investigated by a competent specialist. Attention: observe the maintenance instructions for all components used in the system, such as support frames, charging regulators, inverters, batteries etc.

Suzhou Talesun Solar Technologies Co., Ltd.	Technical specifications	
Installation Manual for European	SPEC.NO.	TS-ET-131
	REVISION	A4
	EFFECTIVE DATE	11-2021
		Page 24 of 25

CHINA

1# Talesun Road, Shajiabang, Changshu, Jiangsu Province, P.R. China 215542

Email: sales@talesun.com/marketing@talesun.com

Web: www.talesun.com

Sales Hotline: +86 400 885 1098

TEL: +86 512 8235 5888

FAX: +86 512 8235 5588

JAPAN

6F, 3-22-1, Toranomom, Minato-ku, Tokyo, Japan (105-0001)

Email: japan@talesun.com

Web: www.talesun.com/?jp

T: +03 5733 3498

F: +03 34341515

USA

25 METRO DRIVE, Suite 228, San Jose, CA, 95 110 USA..

Email: sales@talesun.com

Tel: (408) 638-7627

Fax: (408) 642-1279

UK

Talesun Energy UK Ltd. 42, Upper Berkeley Street, London, W1H5PW United Kingdom

Email: projects@talesunenergy.com

Web: www.talesun-eu.com

Tel: +44 (0)20 3752 6516

GERMANY

Central Tower Munich, Landsberger Strasse 110, 80339 Munich, Germany

Email: info@talesunenergy.com

Web: www.talesun-eu.com

T: +49(0)89- 189 177-0

F: +49(0)89-189-177-499

Suzhou Talesun Solar Technologies Co., Ltd

Address: No. 1 Talesun Road, Changkun Industrial Park, Shajiabang Town, Changshu, Suzhou, Jiangsu Province, 215542, P.R.China

Suzhou Talesun Solar Technologies Co., Ltd.	Technical specifications	
Installation Manual for European	SPEC.NO.	TS-ET-131
	REVISION	A4
	EFFECTIVE DATE	11-2021
		Page 25 of 25

THAILAND

Thai-China Industrial Park in Rayong,

Email: Marketing.hq@talesun.com

TEL: +86 512 8235 5258

FRANCE

2405,Route des Dolines-06560 SophiaAntipolis-France

Email: Sales@talesun.com

TEL: +33 489 82 92 78